

PROPELLER (HARTZELL) - SERVICING**1. General**

- A. This section has the necessary servicing procedures necessary to keep the Hartzell propeller in a serviceable condition.

TASK 12-21-04-640**2. Hartzell Propeller Lubrication****A. General**

- (1) This task gives the procedures to do the lubrication of the Hartzell propeller.

B. Access

- (1) Remove the propeller spinner to get access to the propeller grease fittings. Refer to Chapter 61, Propeller (Hartzell) - Maintenance Practices.

C. Special Tools

- (1) Grease Gun

D. Do the Hartzell Propeller Lubrication (refer to Figure 301).

CAUTION: One zerk fitting must be removed from the clamp to do the lubrication. If it is not removed, too much pressure from the grease gun can rupture the blade clamp seal.

- (1) Remove one grease zerk from each clamp.
(2) Turn the propeller until one of the open zerk ports is as its highest possible point.
(3) Count and record the number of grease gun strokes when you do the lubrication at the initial blade.

NOTE: Servicing the same quantity of grease at each clamp will help keep the static and dynamic balance of the propeller.

- (a) Pump grease into the zerk fitting until clean grease and all moisture is removed from the open zerk fitting port.
(4) Turn the propeller until the next open zerk port is as its highest possible point.
(a) Use the recorded number of grease gun strokes from the initial blade to lubricate the blade.
(5) Turn the propeller until the open zerk port that remains is at its highest possible point.
(a) Use the recorded number of grease gun strokes from the initial blade to lubricate the blade.
(6) Use a clean cloth to remove all excess grease from the propeller.
(7) Install the zerks in the open ports.

A. Restore Access

- (1) Install the propeller spinner. Refer to Chapter 61, Propeller (Hartzell) - Maintenance Practices.

END OF TASK

Figure 301 : Sheet 1 : Propeller (Hartzell) Lubrication

A22876

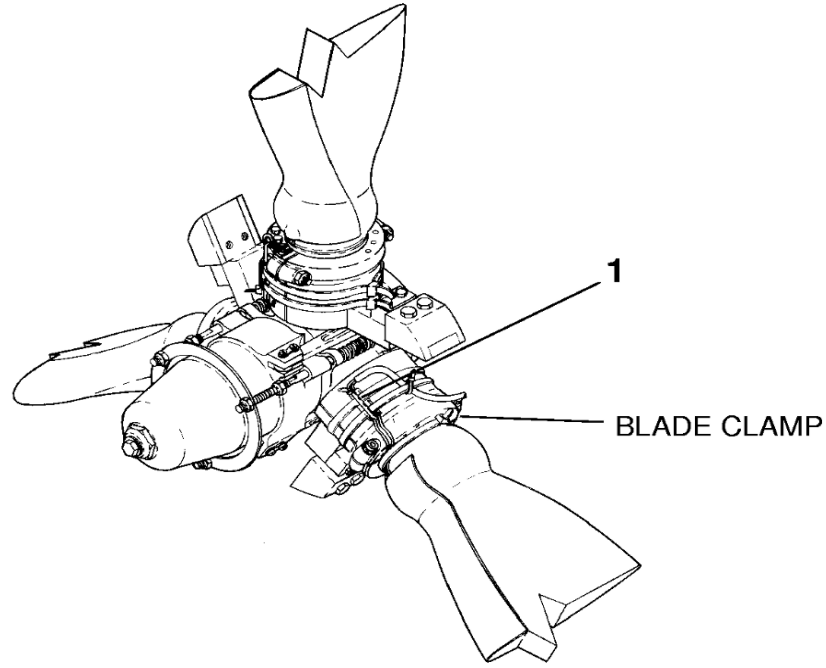

NOTE: TWO ZERKS ARE INSTALLED IN EACH BLADE CLAMP. TO LUBRICATE EACH BLADE, REMOVE ONE ZERK THEN LUBRICATE THE BLADE THROUGH THE OTHER ZERK UNTIL GREASE COMES OUT OF THE OPEN ZERK HOLE.

ITEM NUMBER	ITEM DESCRIPTION	LUBE TYPE	APPLICATION	NUMBER OF FITTINGS IN AREA
1	BLADE CLAMPS	GW	GUN	6

GW - GREASE, MULTI-PURPOSE - (MIL-G-24139)

26142049